



HRE-1250-4 HEAT REACTIVATED DESICCANT AIR DRYER GENERAL ARRANGEMENT

TOLERANCES UNLESS
OTHERWISE SPECIFIED:

- FRACTIONS = ± 1/4 "
- ANGLES = ± 3°
- INCHES = ± 1/2 "
- FINISH = 250

THE SPECIFICATIONS AND DRAWINGS DISCLOSED HEREIN ARE THE SOLE PROPERTY OF ALTEC AIR, AND SHALL NOT BE COPIED OR USED AS THE BASIS FOR SALE OR MANUFACTURE WITHOUT EXPRESS WRITTEN PERMISSION.

REVISION LOG

REV.	ECO.	DESCRIPTION	DATE	APPROVED
C	1062	PRODUCTION UPDATES	12/17/2020	WS

DRAWING NO.

AT20-514

REV.
C

DRAWN: MR
CHECKED:

DATE: 2/18/2015
DATE:

SCALE: N/A

SHEET: 1 OF 2

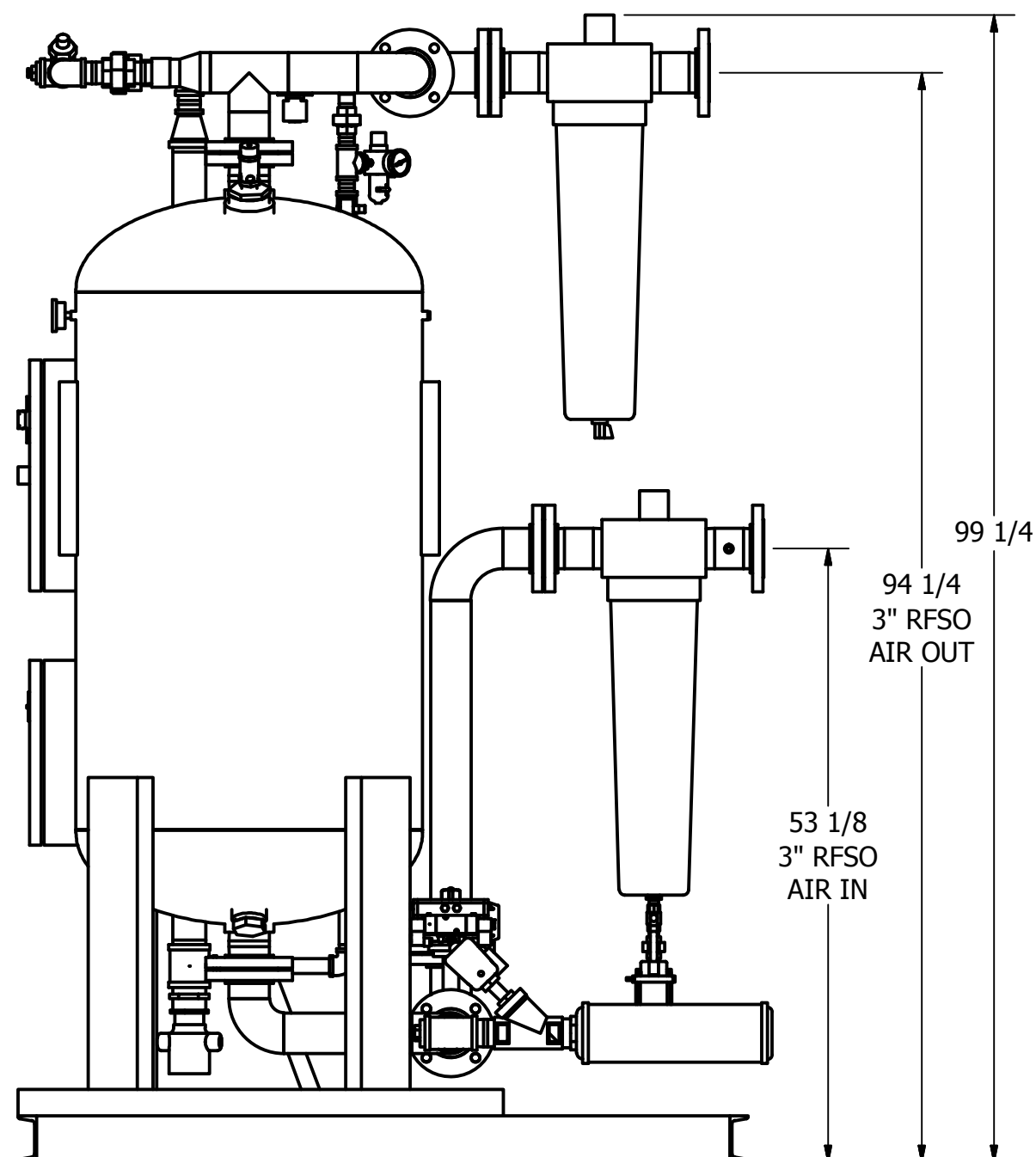
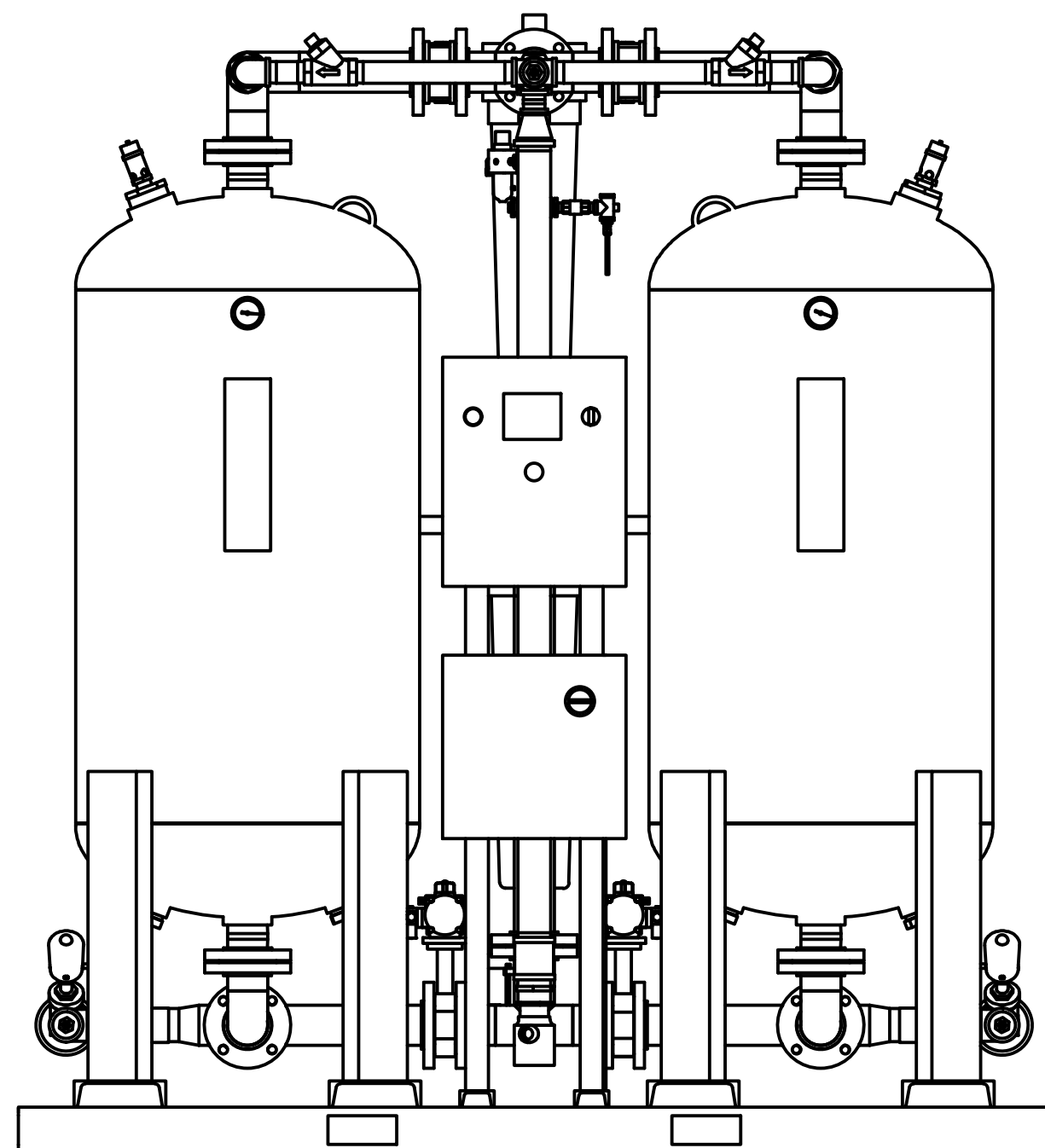
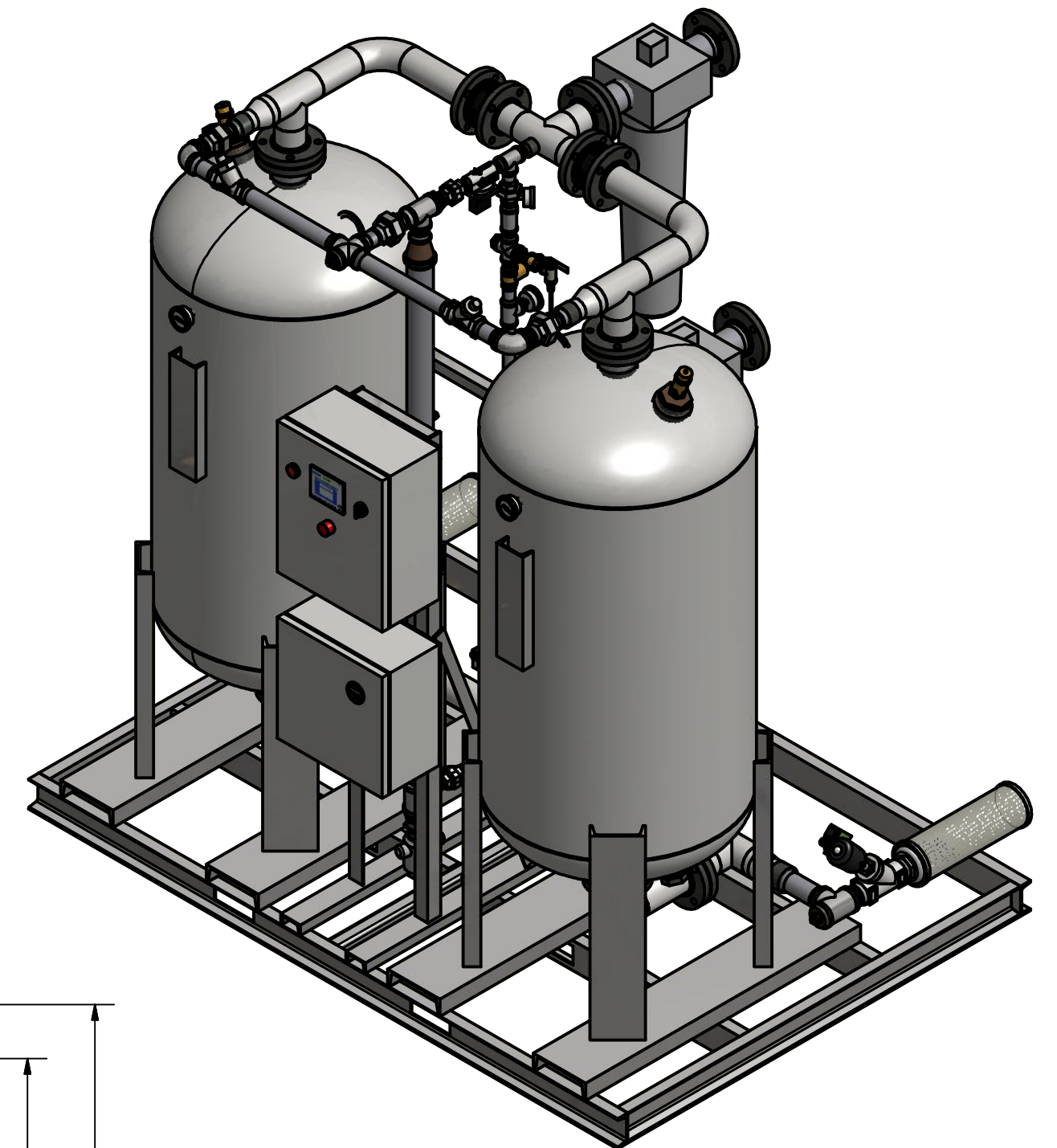
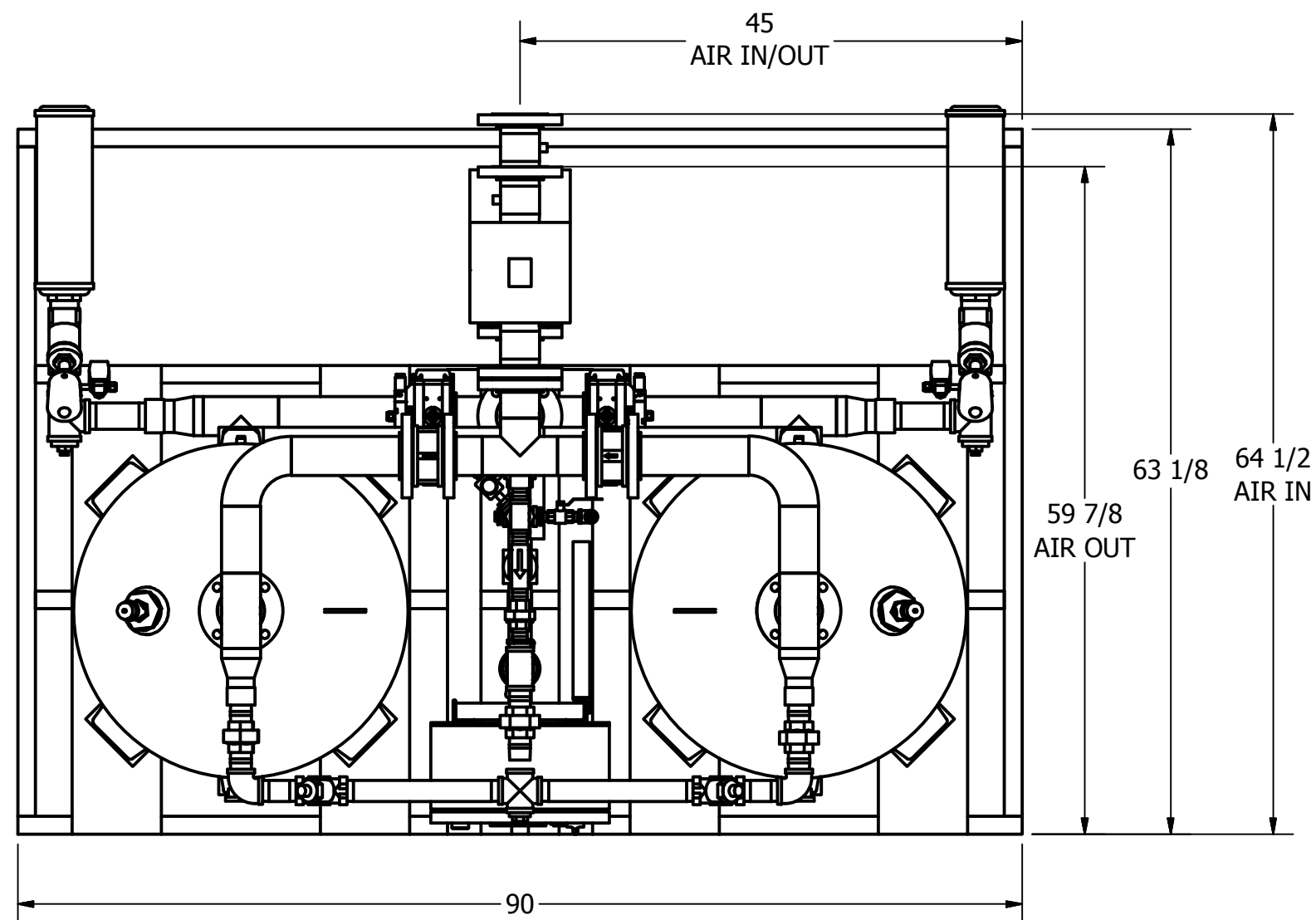

PRELIMINARY



HRE-1250-4 HEAT REACTIVATED DESICCANT AIR DRYER GENERAL ARRANGEMENT

TOLERANCES UNLESS
OTHERWISE SPECIFIED:

FRACTIONS = ± 1/4 "
 ANGLES = ± 3°
 INCHES = ± 1/2 "
 FINISH = 250

THE SPECIFICATIONS AND DRAWINGS DISCLOSED HEREIN ARE THE SOLE PROPERTY OF ALTEC AIR, AND SHALL NOT BE COPIED OR USED AS THE BASIS FOR SALE OR MANUFACTURE WITHOUT EXPRESS WRITTEN PERMISSION.

REVISION LOG

REV.	ECO.	DESCRIPTION	DATE	APPROVED
C	1062	PRODUCTION UPDATES	12/17/2020	WS

DRAWING NO. **AT20-514** REV. **C**

DRAWN: MR DATE: 2/18/2015
 CHECKED: DATE:

SCALE: N/A SHEET: 2 OF 2

PARTS LIST

ITEM	QTY	DESCRIPTION
1	2	CHECK VALVE, PURGE
2	1	SOLENOID VALVE, REPRESS
3	2	CHECK VALVE, OUTLET
4	1	PRESSURE REGULATOR, CONTROL
5	1	PRESSURE GAUGE, CONTROL
6	1	MOISTURE INDICATOR
7	1	GATE VALVE, PURGE
8	1	PARTICULATE AFTER-FILTER
9	1	PRESSURE GAUGE, PURGE
10	1	DEW POINT MONITOR (OPTIONAL)
11	2	RELIEF VALVE, TANK
12	2	PRESSURE GAUGE, TANK
13	1	12 KW HEATER
14	1	COALESCER PRE-FILTER
15	1	ZERO LOSS DRAIN
16	2	BUTTERFLY VALVE, INLET
17	2	ANGLE BODY VALVE, EXHAUST
18	2	MUFFLER, EXHAUST
19	1850 LBS	DESICCANT

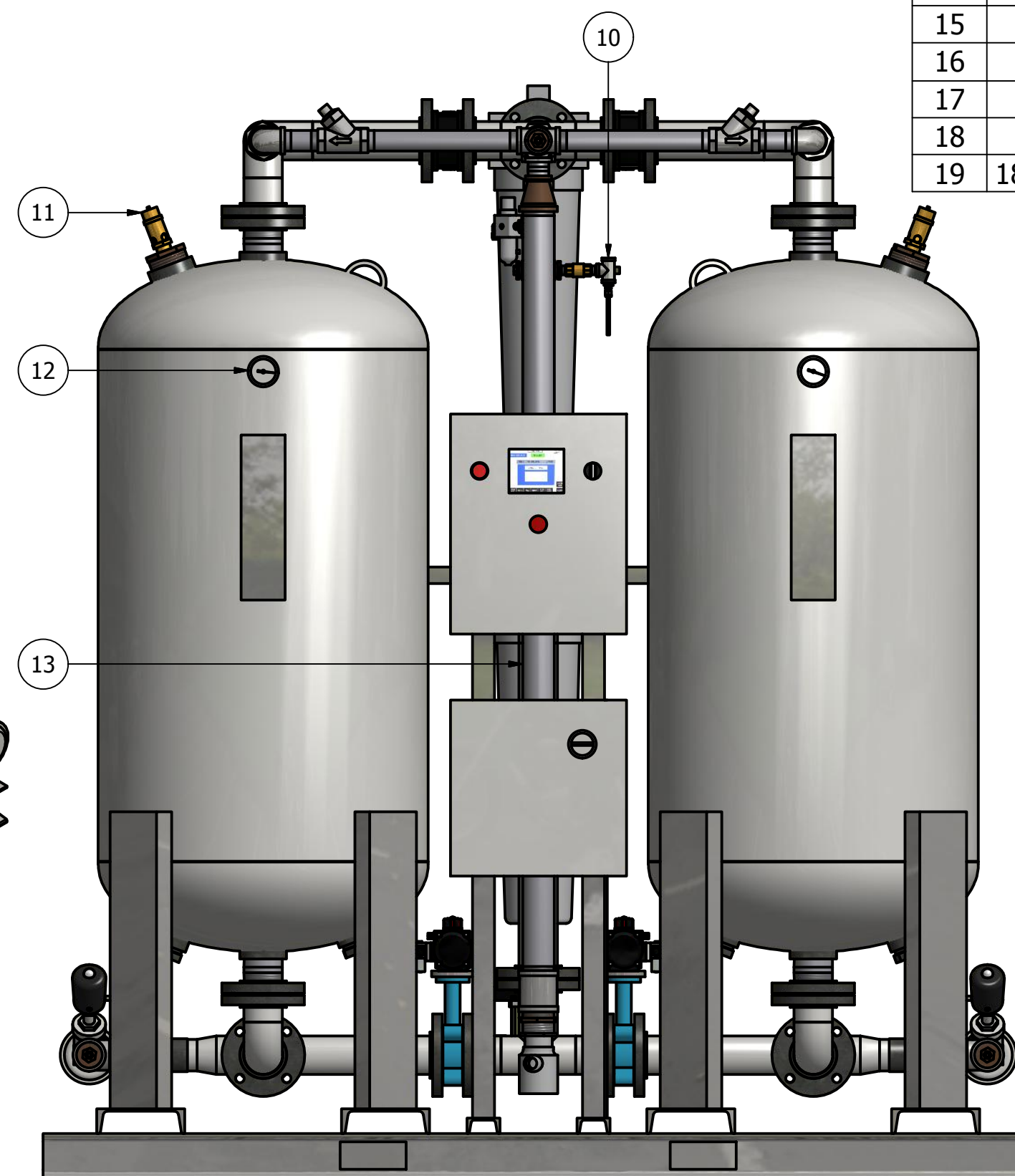
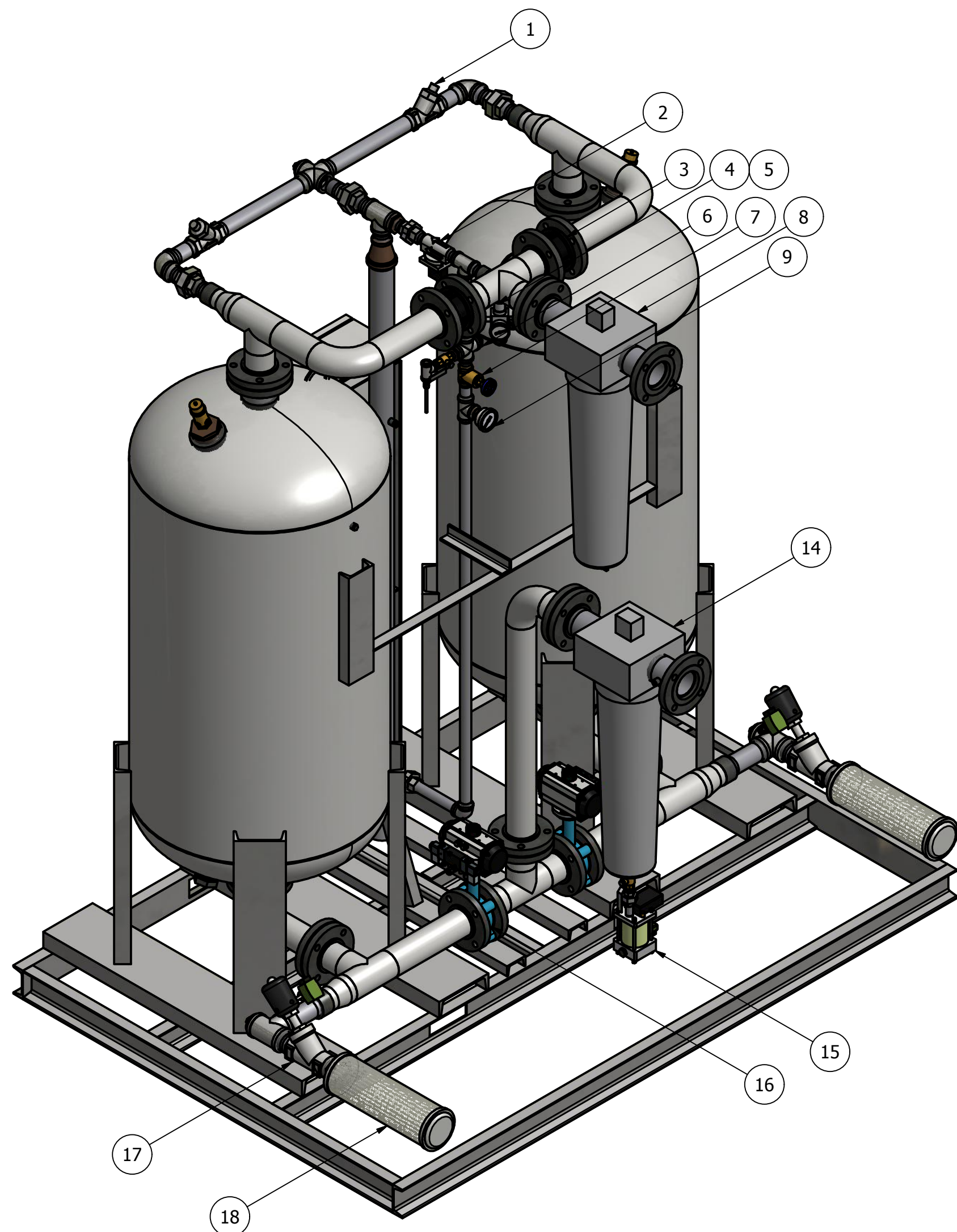

PRELIMINARY